

# SCREW TERMINAL TYPE ALUMINUM ELECTROLYTIC CAPACITORS

**UPGRADE!**

## VGR Series Useful of 4,000 hours at 105°C

• Conform RoHS

### Features

• The permissible ripple current is improved to VG series by approx.60% using low ESR material.

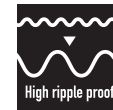
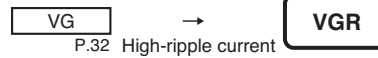

ALUMINUM ELECTROLYTIC CAPACITORS

### Product Specifications

Items	Specifications
Temperature range	-40°C ~ +105°C
Rated voltage	350 ~ 500V.DC
Capacitance tolerance	±20% (20°C, 120Hz)
Leakage current	0.01CV (µA) or 5mA, whichever is smaller or less (20°C, after 5 minutes) [C = nominal capacitance (µF), V = rated voltage (V)]
Dissipation factor	Less than the value specified in the standard products table. (20°C, 120Hz)
Permissible ripple current	As specified in the standard product table. (105°C, 120Hz)
Endurance	After the rated voltage with specified ripple current is applied at 105°C for 2,000 hours : Capacitance change : Within ±15% of the initial value measured Dissipation factor : 175% or less than the initial value specified Leakage current : Less than or equal to the initial value specified
Shelf life	The following specification shall be meet when the capacitor are restored to 20°C after storage of 500 hours at 105°C with no voltage applied. Before the measurement, the capacitor shall be preconditioned by applying the voltage treatment according to Item 4.1 of JIS C 5101-4. Capacitance change : Within ±15% of the initial value measured Dissipation factor : 175% or less than the initial value specified Leakage current : Less than or equal to the initial value specified
Others	JIS C 5101-4

### Dimensions

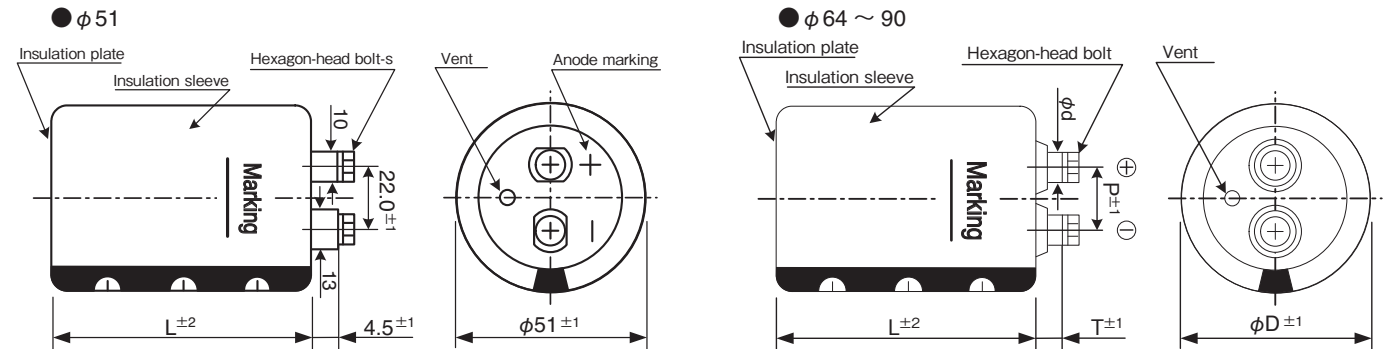

### Ripple current correction coefficient

Temperature (°C)	40	60	85	105	
Correction coefficient	350 ~ 450V.DC	2.10	1.90	1.55	1.00
	500V.DC	2.10	2.00	1.87	1.00
Frequency (Hz)	120	300	1k	≥10k	
	Correction coefficient	1.0	1.1	1.3	1.4
Forced wind (m/s)	<0.5	0.5 ≤			
	Correction coefficient	1.0	1.1		

(unit : mm)

φ D	P	T	φ d	Hexagon-head bolt	Cap material
51	22.0	4.5	—	M5×10	Phenol resin
64	28.6	8.0	11.0	M5×10	Phenol resin
77	31.5	9.0	12.0	M6×12	Phenol resin
90	31.5	8.0	12.0	M6×12	Phenol resin

### Product code

(Example) VGR type 400V 5,600 µF ±20%

**VGR 2G 562 Y F 110**

- VGR: Type of series
- 2G: Case height code
- 562: Case dia code
- Y: Type of bracket code
- F: Capacitance code
- 110: Rated voltage code

Terminal permissible currents : 60Arms for M5; 100Arms for M6.  
Please use this type of capacitor at a terminal current below the permissible.  
Refer to page 21 for product code.

### Bracket

- Refer to page 22-23 for shapes and dimensions.
- Product names in the Standard Products Table correspond to the bracket for Type Y, but Type I bracket may be used (Type of bracket code = I).
- If bracket are not necessary, enter "N" for the type of bracket code.
- Bracket will be delivered separately.

# SCREW TERMINAL TYPE ALUMINUM ELECTROLYTIC CAPACITORS

VGR Series

Standard Products Table

Rated Voltage (V. DC)	Capacitance (μF)	Case size φD×L(mm)	tanδ 20°C, 120Hz	Ripple current (Arms) 105°C, 120Hz	ESR(typ.) (mΩ) 20°C, 100Hz	Z max (mΩ) 20°C, 10kHz	ESL(typ.) (nH)	Product name
350	1,800	51×96	0.20	9.1	54	55	21	VGR2V182YC096
	2,200	51×109	0.20	10.2	44	45	21	VGR2V222YC109
	2,700	51×125	0.20	11.4	36	37	21	VGR2V272YC125
	3,300	64×107	0.20	15.1	29	30	22	VGR2V332YD107
	3,900	64×123	0.20	16.8	24	26	22	VGR2V392YD123
	4,700	64×147	0.20	18.2	20	21	22	VGR2V472YD147
		77×108	0.20	20.6	20	21	24	VGR2V472YE108
	5,600	64×164	0.20	20.3	17	18	22	VGR2V562YD164
		77×124	0.20	23.1	17	18	24	VGR2V562YE124
	6,800	64×187	0.20	22.6	14	15	22	VGR2V682YD187
		77×148	0.20	24.9	14	15	24	VGR2V682YE148
		90×110	0.20	28.6	14	15	24	VGR2V682YF110
	8,200	77×165	0.20	27.9	12	12	24	VGR2V822YE165
		90×150	0.20	31.0	12	12	24	VGR2V822YF150
	10,000	77×188	0.20	31.0	9	10	24	VGR2V103YE188
		90×150	0.20	34.2	9	10	24	VGR2V103YF150
	12,000	77×228	0.20	35.1	8	8	24	VGR2V123YE228
90×167		0.20	36.8	8	8	24	VGR2V123YF167	
15,000	90×190	0.20	41.5	6	7	24	VGR2V153YF190	
18,000	90×230	0.20	44.3	5	6	24	VGR2V183YF230	
22,000	90×268	0.20	45.0	4	5	24	VGR2V223YF268	
400	1,500	51×96	0.20	8.4	63	67	21	VGR2G152YC096
	1,800	51×109	0.20	9.4	53	56	21	VGR2G182YC109
	2,200	51×125	0.20	10.6	43	46	21	VGR2G222YC125
	2,700	64×107	0.20	13.6	35	37	22	VGR2G272YD107
	3,300	64×123	0.20	15.5	29	30	22	VGR2G332YD123
	3,900	64×147	0.20	16.5	24	26	22	VGR2G392YD147
		77×108	0.20	18.8	24	26	24	VGR2G392YE108
	4,700	64×164	0.20	18.6	20	21	22	VGR2G472YD164
		77×124	0.20	21.2	20	21	24	VGR2G472YE124
	5,600	64×187	0.20	20.5	17	18	22	VGR2G562YD187
		77×148	0.20	22.6	17	18	24	VGR2G562YE148
		90×110	0.20	26.0	17	18	24	VGR2G562YF110
	6,800	77×165	0.20	25.4	14	15	24	VGR2G682YE165
		90×150	0.20	28.2	14	15	24	VGR2G682YF150
	8,200	77×188	0.20	28.1	12	12	24	VGR2G822YE188
		90×150	0.20	31.0	12	12	24	VGR2G822YF150
	10,000	77×228	0.20	32.0	9	10	24	VGR2G103YE228
90×167		0.20	33.6	9	10	24	VGR2G103YF167	
12,000	90×190	0.20	37.1	8	8	24	VGR2G123YF190	
15,000	90×230	0.20	40.4	6	7	24	VGR2G153YF230	
18,000	90×268	0.20	40.6	5	6	24	VGR2G183YF268	
450	1,200	51×96	0.20	7.9	79	83	21	VGR2W122YC096
	1,500	51×109	0.20	9.0	64	66	21	VGR2W152YC109
	1,800	51×125	0.20	10.1	53	55	21	VGR2W182YC125
	2,200	64×107	0.20	12.6	43	45	22	VGR2W222YD107
	2,700	64×123	0.20	14.4	35	37	22	VGR2W272YD123
		77×108	0.20	16.1	35	37	24	VGR2W272YE108
	3,300	64×147	0.20	15.6	29	30	22	VGR2W332YD147
		77×124	0.20	18.2	29	30	24	VGR2W332YE124
	3,900	64×164	0.20	17.5	24	26	22	VGR2W392YD164
		77×148	0.20	19.4	24	26	24	VGR2W392YE148
		90×110	0.20	22.3	24	26	24	VGR2W392YF110
	4,700	64×187	0.20	19.3	20	21	22	VGR2W472YD187
		77×148	0.20	21.3	20	21	24	VGR2W472YE148
		90×126	0.20	24.2	20	21	24	VGR2W472YF126
	5,600	77×165	0.20	23.7	17	18	24	VGR2W562YE165
		90×150	0.20	26.3	17	18	24	VGR2W562YF150
	6,800	77×188	0.20	26.3	14	15	24	VGR2W682YE188
90×167		0.20	28.5	14	15	24	VGR2W682YF167	
8,200	77×228	0.20	29.8	12	12	24	VGR2W822YE228	
	90×190	0.20	31.5	12	12	24	VGR2W822YF190	
10,000	90×230	0.20	33.9	9	10	24	VGR2W103YF230	
15,000	90×268	0.20	38.2	6	7	24	VGR2W153YF268	

ALUMINUM ELECTROLYTIC CAPACITORS

# SCREW TERMINAL TYPE ALUMINUM ELECTROLYTIC CAPACITORS

Standard Products Table

Rated Voltage (V. DC)	Capacitance ( $\mu$ F)	Case size $\phi$ D $\times$ L(mm)	$\tan\delta$ 20°C, 120Hz	Ripple current (Arms) 105°C, 120Hz	ESR(typ.) (m $\Omega$ ) 20°C, 100Hz	Z max (m $\Omega$ ) 20°C, 10kHz	ESL(typ.) (nH)	Product name
500	680	51 $\times$ 96	0.20	4.6	153	162	21	VGR2H681YC096
	820	51 $\times$ 109	0.20	5.2	127	134	21	VGR2H821YC109
	1,000	51 $\times$ 125	0.20	5.9	104	110	21	VGR2H102YC125
	1,500	64 $\times$ 107	0.20	8.4	69	73	22	VGR2H152YD107
	1,800	64 $\times$ 123	0.20	9.5	58	61	22	VGR2H182YD123
	2,200	64 $\times$ 147	0.20	10.3	47	50	22	VGR2H222YD147
		77 $\times$ 108	0.20	11.7	47	50	24	VGR2H222YE108
	2,700	64 $\times$ 187	0.20	11.8	39	41	22	VGR2H272YD187
		77 $\times$ 124	0.20	13.3	39	41	24	VGR2H272YE124
	3,300	77 $\times$ 148	0.20	14.4	32	33	24	VGR2H332YE148
		90 $\times$ 110	0.20	16.5	32	33	24	VGR2H332YF110
	3,900	77 $\times$ 165	0.20	15.9	27	28	24	VGR2H392YE165
		90 $\times$ 126	0.20	17.8	27	28	24	VGR2H392YF126
	4,700	77 $\times$ 188	0.20	17.6	22	23	24	VGR2H472YE188
		90 $\times$ 150	0.20	19.4	22	23	24	VGR2H472YF150
	5,600	77 $\times$ 228	0.20	19.8	19	20	24	VGR2H562YE228
		90 $\times$ 167	0.20	20.8	19	20	24	VGR2H562YF167
	6,800	90 $\times$ 190	0.20	23.1	15	16	24	VGR2H682YF190
8,200	90 $\times$ 230	0.20	24.7	13	13	24	VGR2H822YF230	
10,000	90 $\times$ 268	0.20	25.1	11	11	24	VGR2H103YF268	

ALUMINUM ELECTROLYTIC CAPACITORS

## Life time graph

Useful life depending on ambient temperature  $T_a$  and ripple current operating condition  $I$  versus rated ripple current at 105°C, 120Hz

