

Deep UV LED Package

(SCM13AUC00F1Z1)

Product introduction

Sanan SCM13AU series deep ultraviolet packaging product is a kind of compact and large angle package. It's specially designed for lower radiation power application.

Features& benefits

- ü Deep UV LED with emission wavelength between 272 nm and 285 nm
- ü Ultra-compact form factor: 1.3 mm x 1.3 mm x 0.85 mm package
- ü Wide viewing angle >120 deg
- ü High reliability package with ESD protection
- ü Standard SMD Process
- ü RoHS and REACH compliant

Target Application

- ü Water/ Air/ Surface sterilization and disinfection
- ü Food & Pharmaceutical Processing
- ü Medical Spectroscopy
- ü Florescence analyzer
- ü Horticulture lighting

Sanan Optoelectronics

Part Number Nomenclature

The part number of Sanan SCM13AU series deep UV package products is explained as follow:

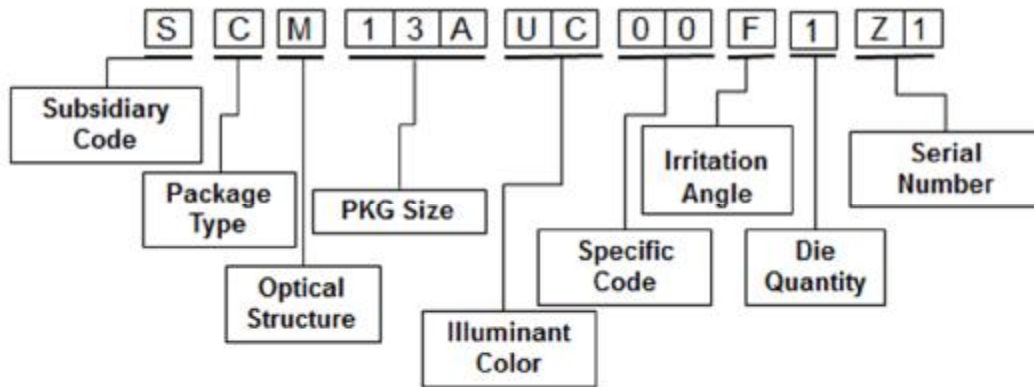

Ordering Information

Part Number: SCM13AUC00F1Z1

Specification nomenclature: reference to Bin Kit Order Codes (wavelength and output radiant power) (272ABC)

Optical and Electrical Characteristics@40mA

Parameter	Symbol	Bin	Minimum	Typical	Maximum	Unit
Peak Wavelength	λ_p	272A	272		285	nm
Output Radiant Power	P_{opt}	BC	2	-	4	mW
		BD	4		6	mW
		BE	6		8	mW
Forward Voltage	V_F		4.5	6.5	7	V
FWHM	$\Delta\lambda$		-	9.6	-	nm
Viewing Angle	$2\theta_{1/2}$		-	150	-	°
Thermal Resistance ($T_j - T_{sp}$)	R_{th}		-	20	-	°C/W

Absolute Maximum Ratings

Parameter	Symbol	Max. Ratings	Units
Forward Current	I_F	60	mA
Reverse Voltage	V_R	-5	V
Operating Temperature	T_{op}	-40 ~ 85	°C
Storage Temperature	T_{stg}	-40 ~ 100	°C
Junction Temperature	T_j	85	°C
Soldering temperature	T_{solder}	260	°C

Optical and Electrical Characteristics Curve

Relative Radiant Power VS Forward Current ($T_a=25\text{ }^\circ\text{C}$)

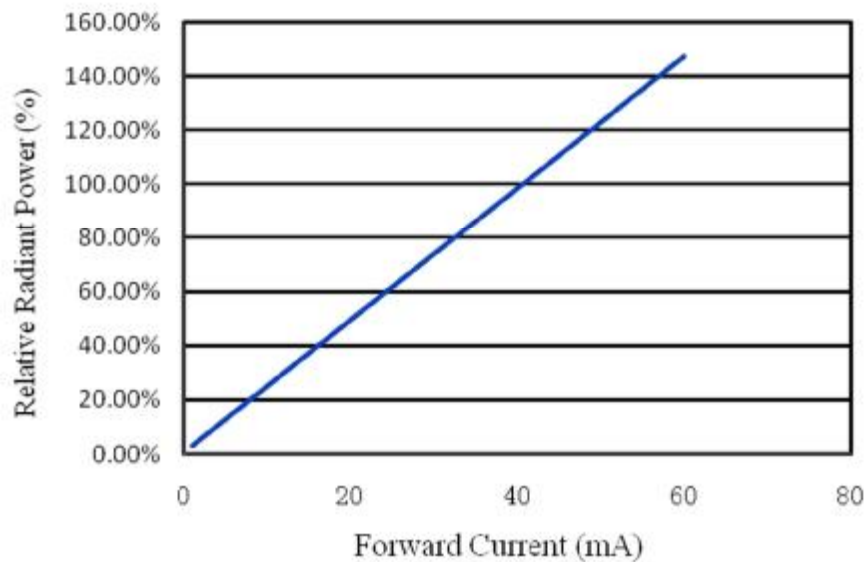



Wavelength Δ VS Forward Current (Ta=25 °C)

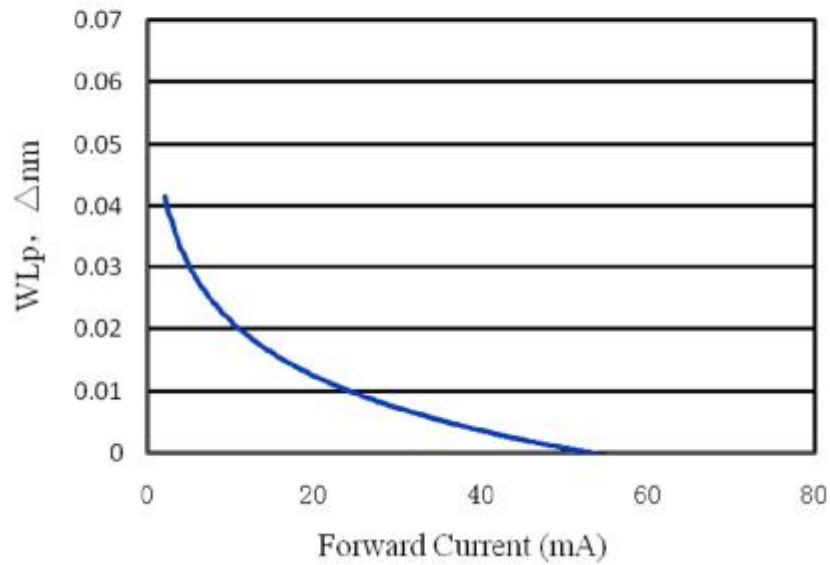

Forward Current VS Forward Voltage (Ta=25 °C)

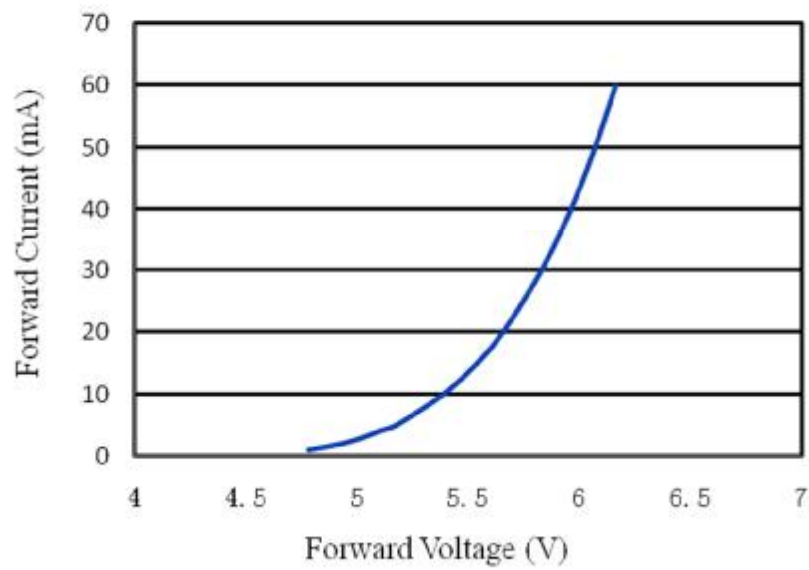

Radiant Pattern

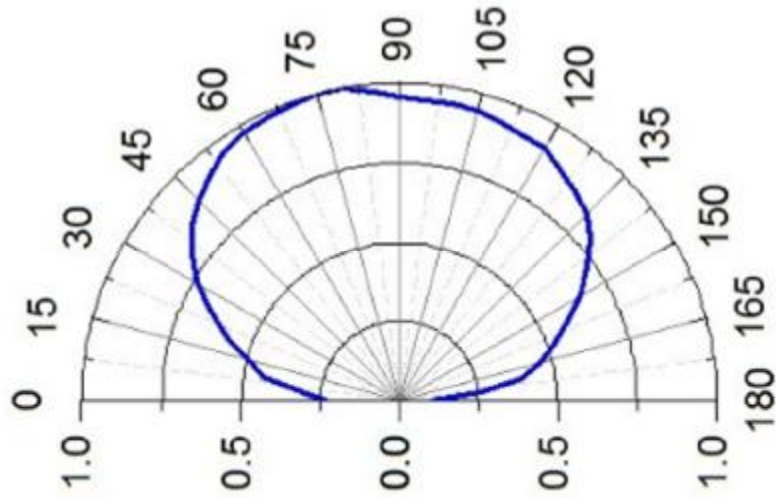

Mechanical Dimension (Unit: mm Tolerance +/-0.1):

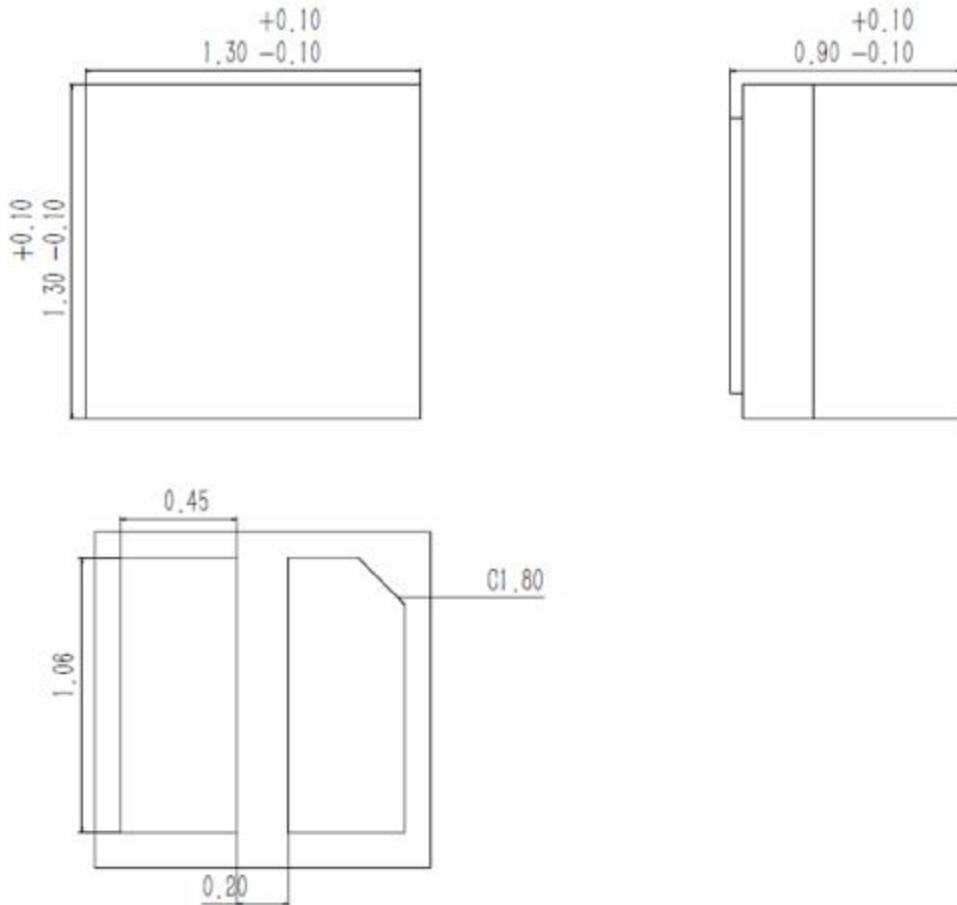

Recommended Stencil Pattern (Unit: mm Tolerance +/- 0.1):

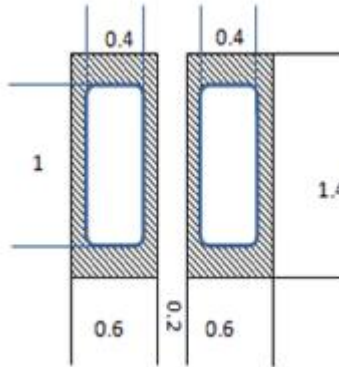

Solder Pad	1.4mm x 0.6mm
Stencil Pattern	1.0mm x 0.4mm

Recommended Reflow Profile

As a general guideline, Sanan recommends that users follow the recommended soldering profile provided by the manufacturer of the solder paste used. Note that this general guideline may not apply to all PCB designs and configurations of reflow soldering equipment.

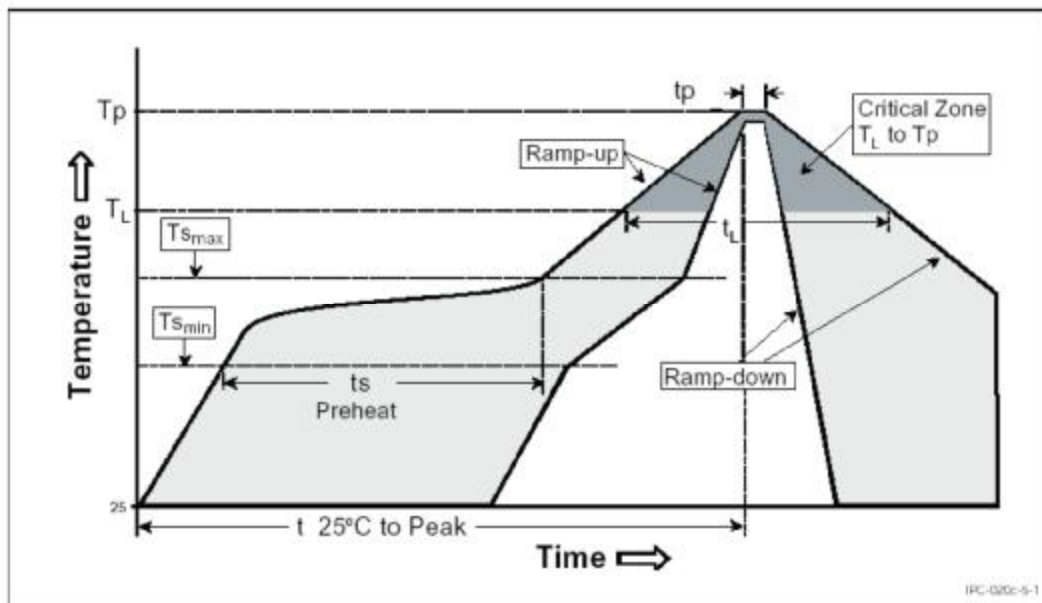

Profile Setting	Pb-Free Profile
Average Ramp-up Rate (T _{max} ,T _p)	1°C/s
Preheat Temperature Min(T _{min})	100-150 °C
Preheat Temperature Max(T _{max})	180-200 °C
Preheat Time (t _{s min} to t _{smax})	60-120s
Liquidus Temperature(T _L)	217 °C
Time Maintained Above Time(t _L)	50-80 s
Peak/Classification Temperature(T _P)	260 °C
Time within 5°C of Actual Peak Temp(t _P)	20-40 s
Ramp-Down Rate	2-3 °C/s
Time25°CPeakTemperature	4 mins

Reliability Test

Item	Conditions	Failure Criteria
Room Temperature Operating Life	25 °C, 20 mA, 1000Hrs	$V_f < 110\%$ $P_{opt} > 70\%$
High Temperature Storage	100 °C, 1000Hrs	
Low Temperature Storage	-40 °C, 1000Hrs	
Temperature Cycles (100cycles)	-40 °C (30 mins) ~ +25 °C (5 mins) +100 °C (30 mins) ~ +25 °C (5 mins)	
ESD (Human Body mode)	R = 1.5 KΩ, C = 100 pF; Test Voltage = 8KV, 3 times negative/positive	
Moisture Sensitive Level(MSL)	3 time reflow, peak temperature +260 °C,10s Pre-conditioning: +30 °C, 60% RH for 192h	
Vibration Test	20 Hz-2000 Hz-20Hz, 200m/s ² , 4cycles,4 min, each X,Y, Z	

Sanan Optoelectronics

Tape & Reel Packaging

(Unit: mm)

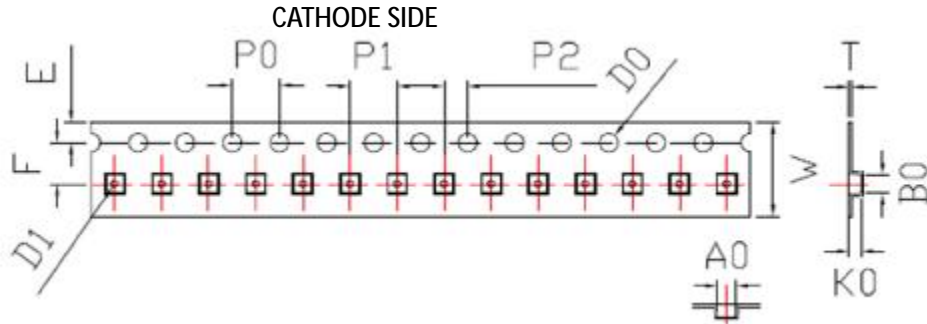

Symbol	A0	B0	K0	P0	P1	P2
Spec	1.55±0.10	1.55±0.10	1.0±0.10	4.00±0.10	4.00±0.10	2.00±0.10
Symbol	W	T	E	F	D0	D1
Spec	8.0±0.20	0.20±0.05	1.75±0.10	3.50±0.10	1.5+0.1/-0	0.6±0.1

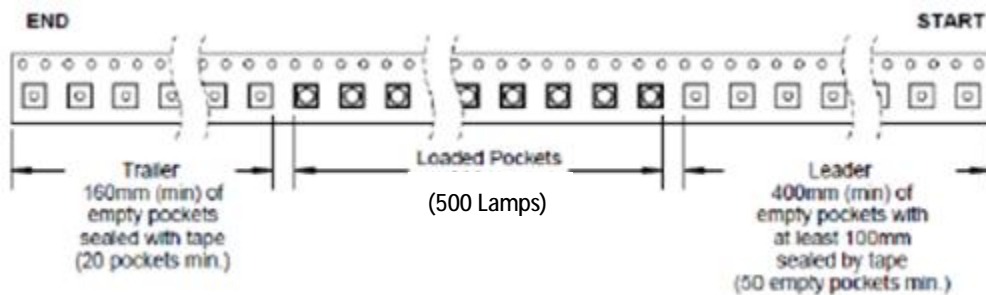
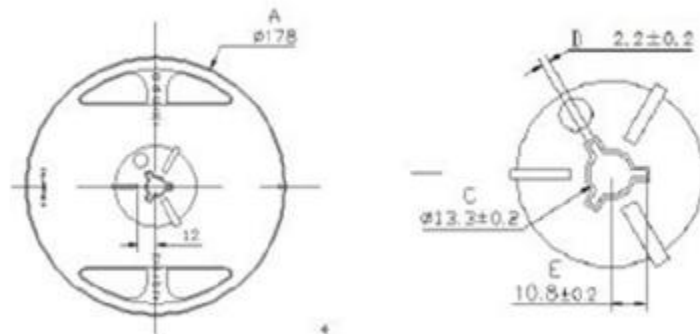

Sanan Optoelectronics

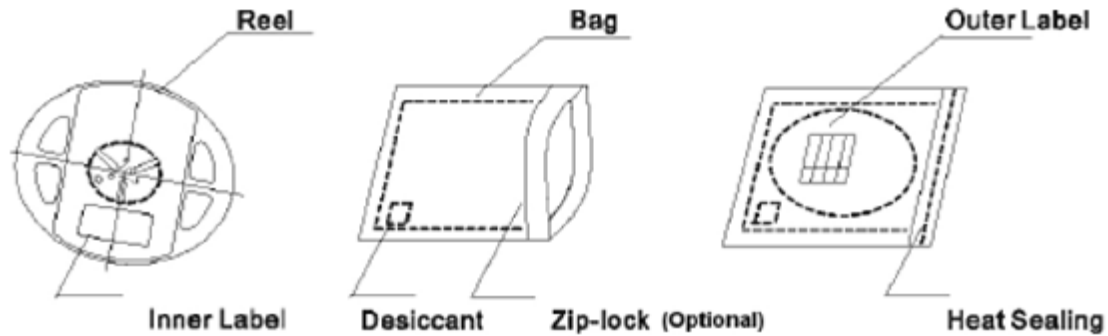

Precautions for storage, handling and use of UV LED components

UV Light

These devices are short wavelength Ultraviolet LED. During operation, the LED emits high intensity ultraviolet (UV) light, which is harmful to skin and eyes.

UV light is hazardous to skin and may cause cancer. Avoid exposure to UV light when LED is operational.

Precautions must be taken to avoid looking directly at the UV light without the use of UV light protective glasses. Do not look directly at the front or at the LED's lens when LED is operational.

Static Electricity (ESD)

Despite with built-in Zener protection diodes, UV LED are particularly sensitive to ESD (Electrostatic Discharge); static electricity and surge voltages seriously damage UV LEDs and can result in complete failure of the device. Precautions must be taken against ESD when handling or operating these devices.

Operating Conditions

In order to ensure the correct functioning of these LEDs, compliance to the typical electrical specifications is paramount. UV LEDs are particularly sensitive to any current value that exceed the max operating specifications, and will cause damage and possible complete failure to the device. The use of current regulated drive circuits are strongly recommended when operating these devices. These LEDs are susceptible to heat generation. Provide adequate thermal management to ensure LEDs do not exceed maximum recommended temperatures. Operating LEDs at temperatures in excess of specification will result in damage and possible complete failure of the device.

The following warning labels are attached to the product/system using ultraviolet.



Label information

Sanan Optoelectronics



PN:SCM13AUC00F1Z1

Bin Cd:275ABD

Lot Cd:UN19060500001

QTY:50

WIP ID:US201906140001