

Deep UV LED Package (SCF35BUC00E1Z1)

Product introduction

Sanan SCF35BUC series deep ultraviolet packaging products are a kind of organic package. It's specially designed for mid radiation power application.

Features& benefits

- ü Deep UV LED with emission wavelength between 275 nm and 285 nm
- ü Industry standard 3.5mm x 3.5mm ceramic package
- ü Wide viewing angle >130 deg
- ü High reliability package with ESD protection
- ü Standard SMD Process
- ü RoHS and REACH compliant

Target Application

- ü Water/ Air/ Surface sterilization and disinfection
- ü Food & Pharmaceutical Processing
- ü Medical Spectroscopy
- ü Florescence analyzer
- ü Horticulture lighting

Part Number Nomenclature

The part number of Sanan SCF35BUC series deep UV package products is explained as follow:

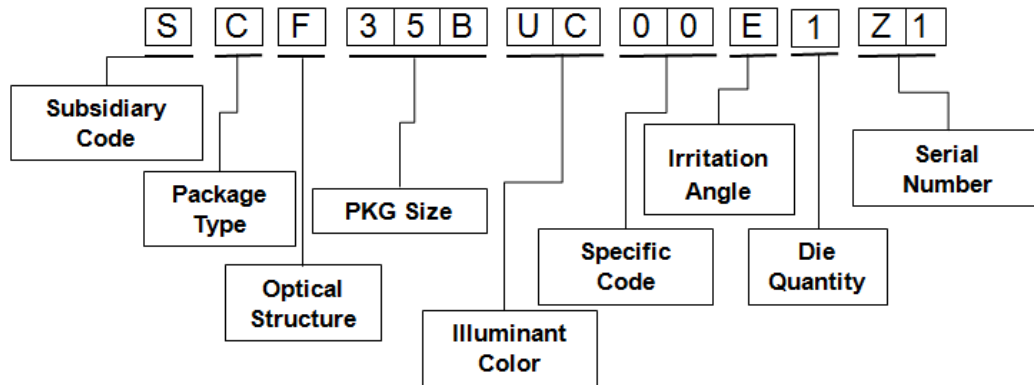

Ordering Information

Part Number: SCF35BUC00E1Z1

Specification nomenclature: reference to Bin Kit Order Codes (wavelength and output radiant power) (275BD8B55)

Optical and Electrical Characteristics@100mA

Parameter	Symbol	Bin	Minimum	Typical	Maximum	Unit
Peak Wavelength	λ_P	275B	275	-	280	nm
		280B	280	-	285	nm
Output Radiant Power	P_{opt}	D8	8	-	13	mW
		D13	13	-	18	mW
		D18	18	-	23	mW
Forward Voltage	V_F	B55	5.5	-	6	V
		B60	6	-	6.5	V
		B65	6.5	-	7	V
FWHM	$\Delta\lambda$	-	-	10.5	-	nm
Viewing Angle	$2\theta_{1/2}$	-	-	137	-	°
Thermal Resistance ($T_j - T_{sp}$)	R_{th}	-	-	-	-	-

Absolute Maximum Ratings

Parameter	Symbol	Max. Ratings	Units
Forward Current	I_F	100	mA
Reverse Voltage	V_R	-5	V
Operating Temperature	T_{op}	-40 ~ 85	°C
Storage Temperature	T_{stg}	-40 ~85	°C
Junction Temperature	-	-	°C
Soldering temperature	T_{solder}	260	°C

Optical and Electrical Characteristics Curve

Relative Radiant Power VS Forward Current (Ta=25 °C)

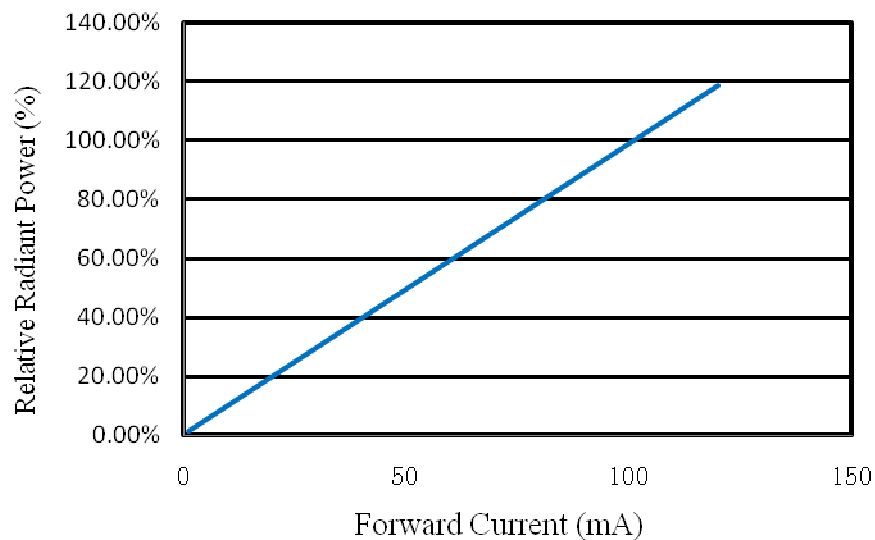

Forward Current VS Forward Voltage (Ta=25 °C)

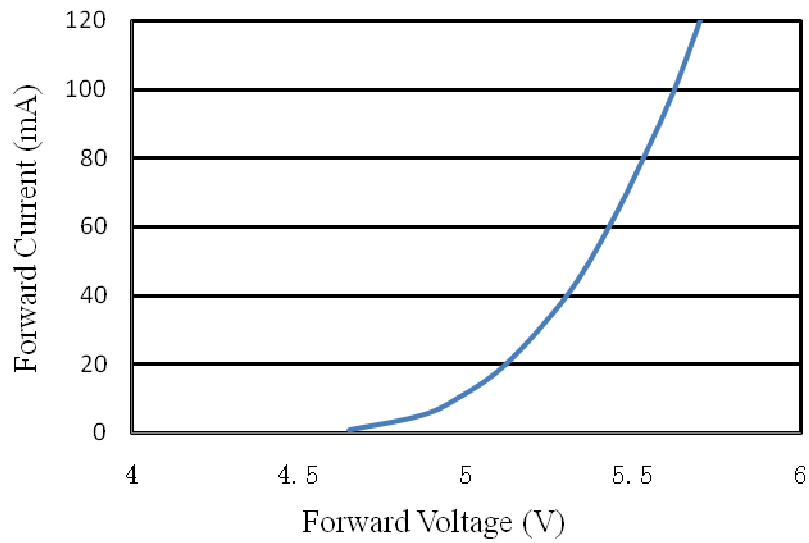

Wavelength Δ Vs Forward Current (Ta=25°C)

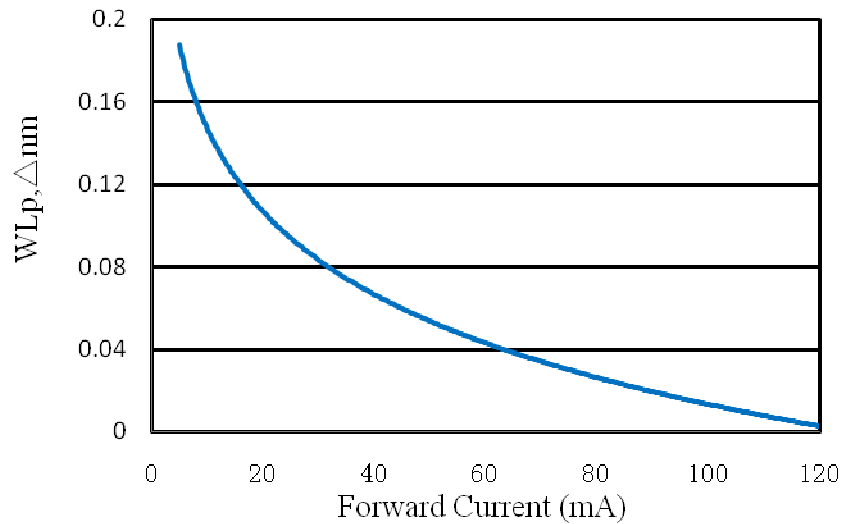

Radiant Pattern

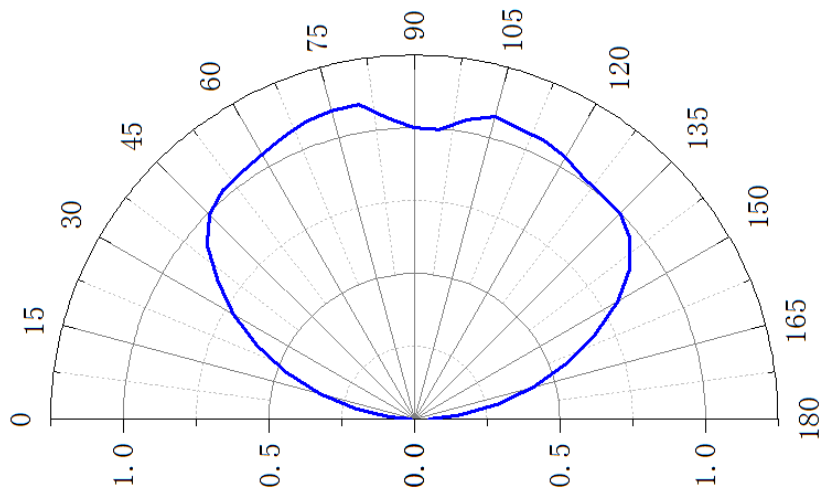

Mechanical Dimension (Unit: mm Tolerance +/-0.1):

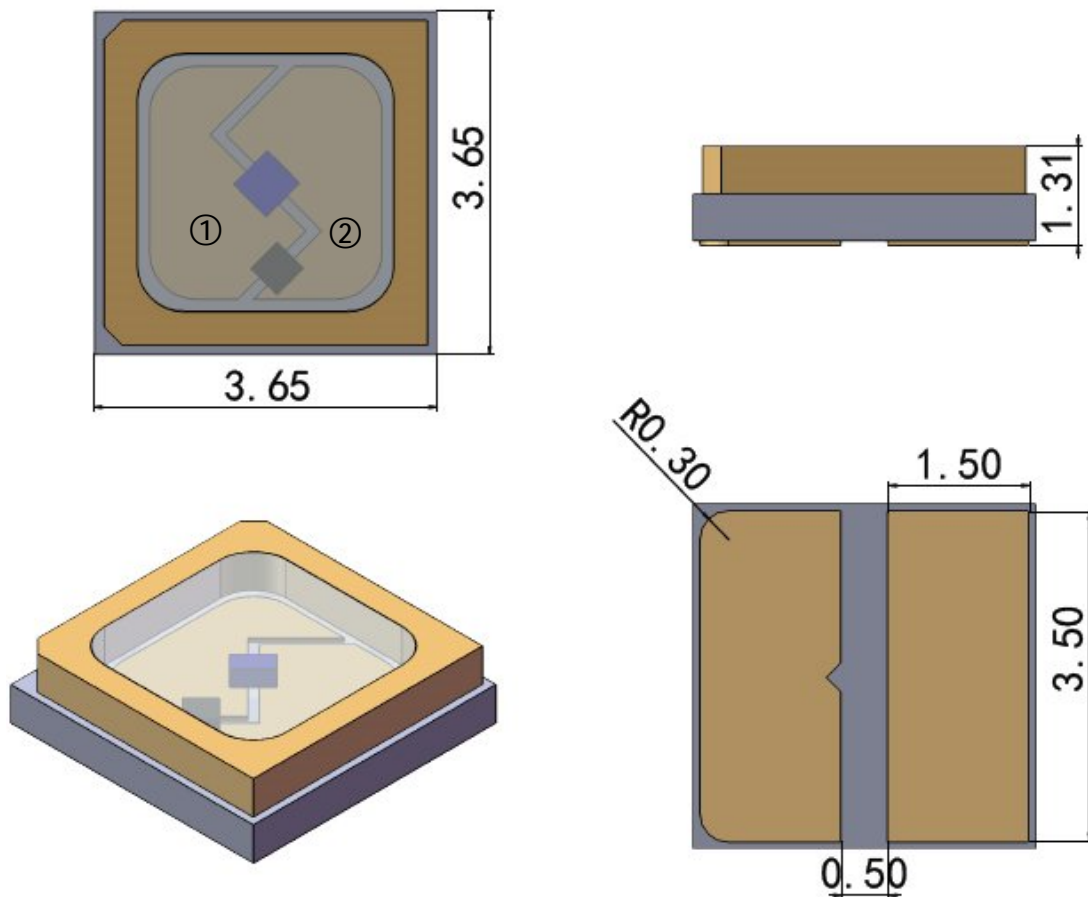

Notes: ① Cathode Pad, ② Anode Pad

Recommended Stencil Pattern (Unit: mm Tolerance +/- 0.1):

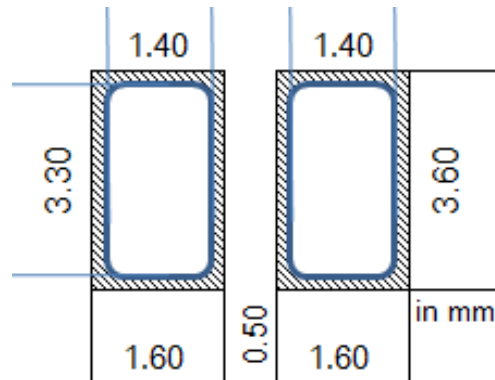

Solder Pad	3.6 mm x 1.6mm
Stencil Pattern	3.3mm x 1.4mm

Recommended Reflow Profile

As a general guideline, Sanan recommends that users follow the recommended soldering profile provided by the manufacturer of the solder paste used. Note that this general guideline may not apply to all PCB designs and configurations of reflow soldering equipment.

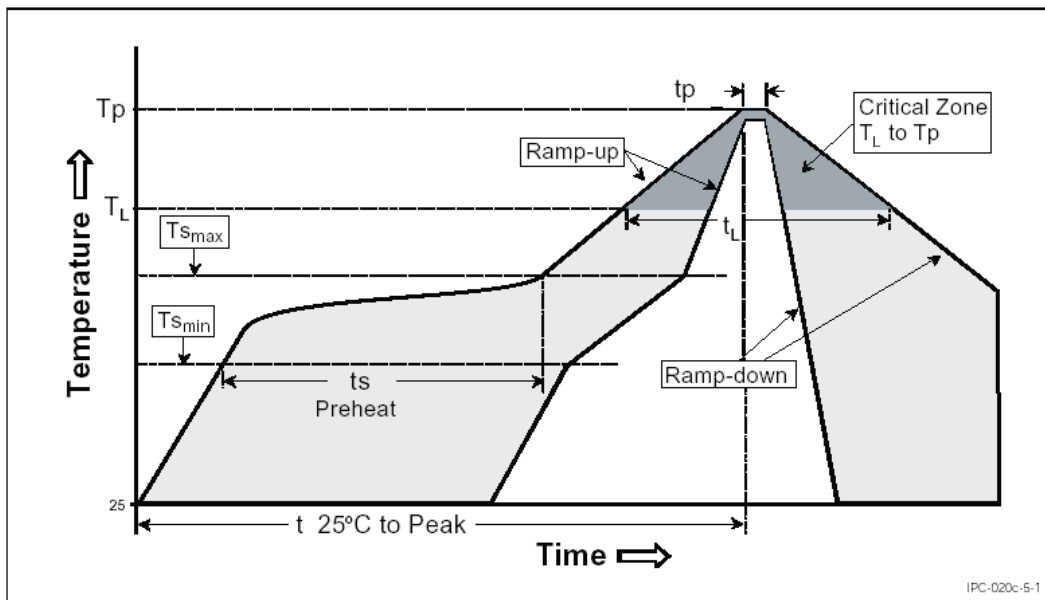

Profile Setting	Pb-Free Profile
Average Ramp-up Rate (T _{max} ,T _p)	1°C/s
Preheat Temperature Min(T _{min})	100-150 °C
Preheat Temperature Max(T _{max})	180-200 °C
Preheat Time (t _{s min} to t _{s max})	60-120s
Liquidus Temperature(T _L)	217 °C
Time Maintained Above Time(t _L)	50-80 s
Peak/Classification Temperature(T _P)	260 °C
Time within 5°C of Actual Peak Temp(t _P)	20-40 s
Ramp-Down Rate	2-3 °C/s
Time25°CPeakTemperature	4 mins

Tape & Reel Packaging

(Unit: mm)

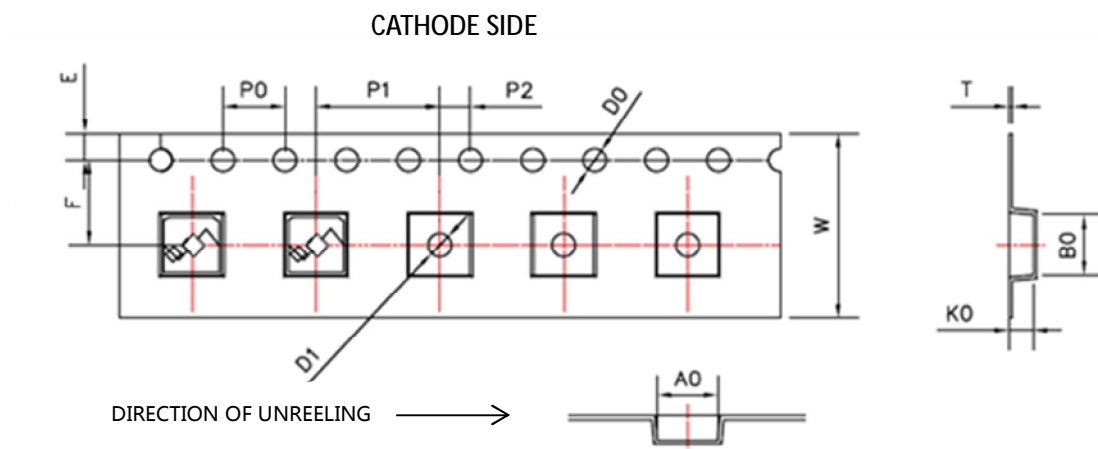

Symbol	A0	B0	K0	P0	P1	P2
Spec	3.90±0.10	3.95±0.10	1.60±0.10	4.00±0.10	8.00±0.10	2.00±0.10
Symbol	W	T	E	F	D0	D1
Spec	12.00±0.30	0.25±0.05	1.75±0.10	5.50±0.10	1.5+0.1/-0	1.5±0.10

Sanan Optoelectronics

Tape and Reel

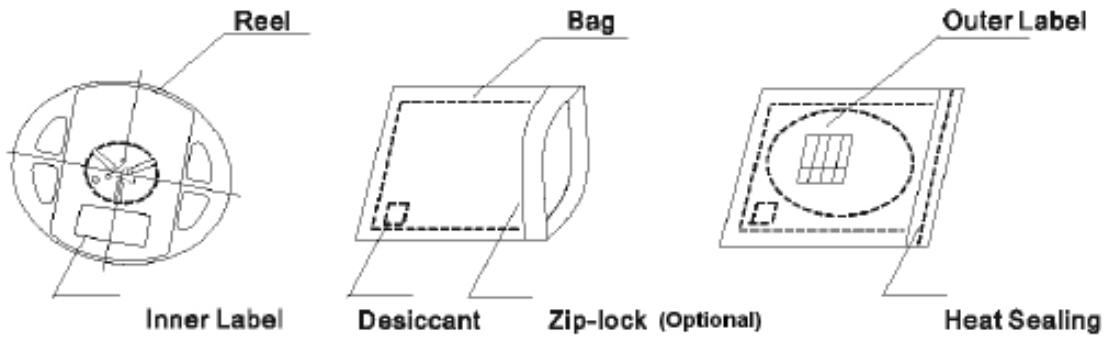
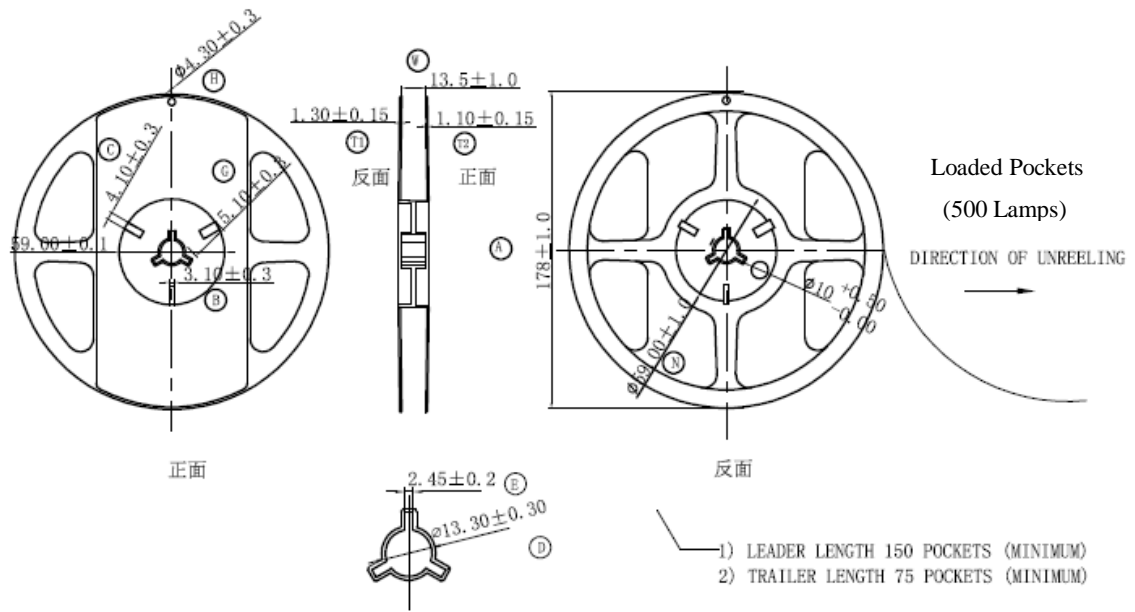

Precautions for storage, handling and use of UV LED components

UV Light

These devices are short wavelength Ultraviolet LED. During operation, the LED emits high intensity ultraviolet (UV) light, which is harmful to skin and eyes.

UV light is hazardous to skin and may cause cancer. Avoid exposure to UV light when LED is operational.

Precautions must be taken to avoid looking directly at the UV light without the use of UV light protective glasses. Do not look directly at the front or at the LED's lens when LED is operational.

Static Electricity (ESD)

Despite with built-in Zener protection diodes, UV LED are particularly sensitive to ESD (Electrostatic Discharge); static electricity and surge voltages seriously damage UV LEDs and can result in complete failure of the device. Precautions must be taken against ESD when handling or operating these devices.

Operating Conditions

In order to ensure the correct functioning of these LEDs, compliance to the typical electrical specifications is paramount. UV LEDs are particularly sensitive to any current value that exceed the max operating specifications, and will cause damage and possible complete failure to the device. The use of current regulated drive circuits are strongly recommended when operating these devices. These LEDs are susceptible to heat generation. Provide adequate thermal management to ensure LEDs do not exceed maximum recommended temperatures. Operating LEDs at temperatures in excess of specification will result in damage and possible complete failure of the device.

The following warning labels are attached to the product/system using ultraviolet.



Label information

Sanan Optoelectronics

PN: SCF35BUC00E1Z1

Spec: 275BD8B55

Lot Cd: UN1803220001

WIP ID: CS1907260001



	Min	Avg	Max	
PO:	8	10	13	[mw]
WP:	275	278	280	[nm]
VF:	5.5	5.8	6	[V]



I (mA) : 100

QTY: 500 